

EPIDEMIOLOGICAL APPROACH TO THE SOUTH KOREAN BEEF PROTESTS WITH HIDDEN AGENDA

TAE SUG DO^{1†} AND YOUNG S LEE²

¹DEPARTMENT OF MATHEMATICS EDUCATION, KWANDONG UNIVERSITY, KANGLEUNG, SOUTH KOREA
E-mail address: taesdo@kwandong.ac.kr

²DEPARTMENT OF MATHEMATICS AND COMPUTER SCIENCE, MANCHESTER COLLEGE, INDIANA, USA
E-mail address: yslee@manchester.edu

ABSTRACT. Hundreds of thousands of South Korean protesters staged candlelight vigils and demonstrations against US beef imports in 2008. The problems, however, went far beyond that of beef imports. The political party veterans, who lost the presidential election, exploited labor unions that were discontent with the economy and ideological student groups to weaken the majority party. In this study, an epidemiological model is constructed with a system of three nonlinear differential equations. The model seeks to examine the dynamics of the system through stability analysis. Two threshold conditions that spread the protests are identified and a sensitivity analysis on the conditions is performed to isolate the parameters to which the system is most responsive. The results are also explored by deterministic simulations. This model can be easily modified to apply to other protests that may occur in various circumstances.

1. INTRODUCTION

South Korea ("Korea") banned most U.S. beef imports in 2003 due to fears of mad cow disease (BSE) [1] after two BSE-infected cows were identified, one born in U.S. and one in Canada [2]. U.S. lawmakers had pressed the Korean government to lift the restrictions on beef imports before approving a free trade agreement between two nations.

The new Korean president who was inaugurated in February 2008 agreed to relax the restrictions on beef imports from the U.S. in April. The Japanese government soon followed Korea on relaxing regulations on U.S. beef imports and Koreans realized that their deal was not as effective as the Japanese one. For example, the Korean government allowed the imports of beef from U.S. cattle 30 months old or younger, but the Japanese government limited the age of cattle to 20 months or younger, which is thought to be potentially less at risk from the disease. Extensive media reporting on BSE and American beef imports of which some were exaggerated and not even supported by science created paranoia surrounding infected U.S. beef [3].

Received by the editors December 16 2008; Accepted June 2 2009.

2000 *Mathematics Subject Classification.* 37N25.

Key words and phrases. Epidemiological Model, Beef Protests.

[†] Corresponding author.

The first candlelight vigil concerning relaxed regulations was on May 2 and thousands of protesters rallied almost nightly for more than a month. Demonstrations continued even with scientific facts and international assurance of safety of U.S. beef. As protesters became aggressive and violent, it was clear that the problems went far beyond that of beef imports and the Korean police began to arrest some protesters.

The new president had been elected with the biggest margin of victory in decades. Although the citizens in Korea had high expectations from the new president, soaring gas prices in April and the global credit crisis began affecting Korea resulting in significant job losses. Many Koreans viewed the deal of relaxed regulations on beef imports as an embarrassing concession to the US and thought that the new president compromised public health standards to improve Korea - U.S. relations. The beef deal triggered public discontent with the worsening economy and political turmoil and provided outlet to express doubts on the governing style of the new administration. The political party veterans, who lost the presidential election, exploited labor unions that were discontent with the economy and ideological student groups to weaken the majority party. Hundreds of thousands of Koreans participated in candlelight vigils and demonstrations; it was an epidemic.

In this study, we take a modeling approach to the situation and construct an epidemiological model with ordinary differential equations to examine the dynamics of the protests. [4] and [5] modeled social phenomena using contact interactions and the theory of random nets, respectively. We assume that during the events of all of the beef protesting, individuals are encouraged and persuaded to participate in candlelight vigils and demonstrations through peer pressure and the media similar to epidemics in a population. Through the stability analysis we identify threshold conditions that describe the different scenarios for the protests. We perform a sensitivity analysis on the threshold conditions to isolate the parameters to which our system is most responsive. Our system produces a backward bifurcation. We explore our results through deterministic simulations.

2. MODEL

Our model consists of three classes, susceptible (S), demonstrating (D), and leading (L). Individuals in D participate in candlelight vigils and demonstrations, but they do not lead a protest, whereas individuals in L organize protests and recruit L members from the D class in addition to participating in protests. The total population is $N = S + D + L$. Since the system is considered for only one hundred days, we assume that there is no birth or death coming into or leaving the system. Individuals move among the classes by a number of different processes. The parameter α is the peer driven recruitment rate of S into D by individuals in D and L . Individuals in L are ξ times as effective in recruiting susceptible as individuals in D . The linear term ϕ represents the role of the secondary source that moves individuals in D to S such as reports on the safety of American beef from international news programs, no more time to protest, or being arrested among others. The primary contact in the transition of demonstrators to the susceptible class is via the δ term. Demonstrators transit to the L class at rate $\gamma DL/N$. η is the rate at which individuals in L moving back to S . Individuals in L may have distinct

reasons to stage protests or distinct goals to achieve by organizing protests. Hence, some may move back to the S class when they obtained what they desired, and some may get arrested. For sociological reasons, we assume that $\delta < \alpha$ and $\phi > \eta$. Our unit time is a day. These are summarized in schematic form in Figure 1.

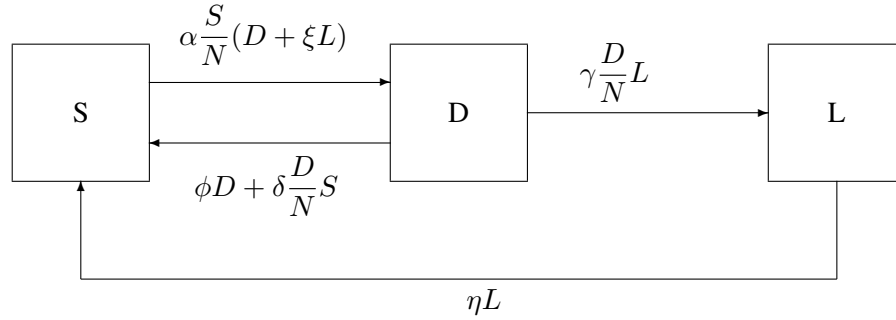

FIGURE 1. A schematic diagram of the model

Under these assumptions the governing compartmental model is the following system.

$$\begin{aligned}
 \frac{dS}{dt} &= -\alpha \frac{S}{N}(D + \xi L) + \phi D + \delta \frac{D}{N}S + \eta L \\
 \frac{dD}{dt} &= \alpha \frac{S}{N}(D + \xi L) - \phi D - \delta \frac{D}{N}S - \gamma \frac{D}{N}L \\
 \frac{dL}{dt} &= \gamma \frac{D}{N}L - \eta L \\
 N &= S + D + L
 \end{aligned} \tag{2.1}$$

3. ANALYSIS

3.1. Rescaling the System of Equations. We define our variables as proportions of the entire population by letting $s = S/N$, $d = D/N$, and $l = L/N$. Then the last equation of the system (1) provides $d = 1 - s - l$ and we obtain a rescaled system of ordinary differential equations.

$$s' = (1 - s - l)(-\alpha s + \phi + \delta s) + l(-\alpha \xi s + \eta) \tag{3.1}$$

$$l' = l\gamma(1 - s - l) - \eta l \tag{3.2}$$

3.2. Equilibria and Stability. We set equations (2) and (3) equal zero and solve for equilibria. There are four possible equilibria: the susceptible-only equilibrium (SOE), the leader-free equilibrium (LFE), and two endemic equilibria (EE). In order to analyze the stability of the system at each equilibrium we linearize the system. By computing partial first derivatives with respect to each of the variables s and l , we obtain the Jacobian for the system

$$J = \begin{bmatrix} (\alpha - \delta)s - \phi + (1 - s - l)(\delta - \alpha) - \alpha \xi l & s(\alpha - \delta) - \phi - \alpha \xi s + \eta \\ -\gamma l & \gamma(1 - s) - 2\gamma l - \eta \end{bmatrix}.$$

Applying J to the SOE $(1,0)$, we find that the eigenvalues are negative if $\frac{\alpha - \delta}{\phi} < 1$. Define

$$R_1 = \frac{\alpha - \delta}{\phi} \quad (3.3)$$

Then the SOE is locally asymptotically stable if $R_1 < 1$. R_1 describes an average number of susceptibles that an individual in D would convert if dropped in a homogeneous population of susceptibles. It is the multiplication of $\alpha - \delta$, the net pressure on susceptibles by individuals in D , and $1/\phi$, the average time spent in the D class.

The LFE $(1/R_1, 0)$ exists when $R_1 > 1$. Define

$$R_2 = \frac{\gamma}{\eta} \left(1 - \frac{1}{R_1}\right). \quad (3.4)$$

The Jacobian J evaluated at the LFE has negative eigenvalues if $R_2 < 1$. Hence, the LFE exists and is locally asymptotically stable if $R_1 > 1$ and $R_2 < 1$. R_2 is the multiplication of the average time spent in L , the proportion of the population D in N , and the rate of conversion from D to L . Hence, R_2 is interpreted as the average number of demonstrators that an individual in L would convert. R_2 measures how serious the effect of L to D is.

In order to discuss two endemic equilibria, we first obtain $l^* = 1 - s^* - \eta/\gamma$ from setting equation (3.2) equal zero and substitute this in equation (3.1), $s' = 0$, to solve for s^* . Define the following:

$$\begin{aligned} A &= \alpha\xi \\ B &= \frac{\eta}{\gamma}(\delta - \alpha) - \eta - \alpha\xi\left(1 - \frac{\eta}{\gamma}\right) \\ C &= \eta\left(\frac{\phi}{\gamma} + 1 - \frac{\eta}{\gamma}\right) \\ f(s) &= As^2 + Bs + c \end{aligned}$$

Note that $f(0) = c > 0$, $f'(0) = B < 0$, $f(1) > 0$, and $f'(1) > 0$. Hence, two solutions s^* to $f(s) = 0$ exist if $B^2 - 4AC > 0$. I.e., if

$$R_3 \equiv \frac{\eta}{\gamma}(\alpha - \delta) + \eta + \alpha\xi\left(1 - \frac{\eta}{\gamma}\right) - 2\sqrt{\alpha\xi\eta\left(\frac{\phi}{\gamma} + 1 - \frac{\eta}{\gamma}\right)}$$

is positive, two EE exist. To determine the stability of these equilibria, we apply the Jury criteria [6]. The Jacobian J applied to these EE has the following determinant and trace:

$$\begin{aligned} tr(J) &= (\delta - \alpha)s^* + \phi + (\alpha - \delta)\frac{\eta}{\gamma} + \alpha\xi\left(1 - s^* - \frac{\eta}{\gamma}\right) + \gamma\left(1 - s^* - \frac{\eta}{\gamma}\right) \\ det(J) &= (\alpha - \delta)\frac{\eta}{\gamma} + \alpha\xi\left(1 - s^* - \frac{\eta}{\gamma}\right) - \alpha\xi s^* + \eta \end{aligned}$$

It is easily seen that $tr(J)$ is always negative. Note that $det(J) > 0$ if and only if

$$s^* < \frac{1}{2\alpha\xi} \left[(\alpha - \delta)\frac{\eta}{\gamma} + \alpha\xi\left(1 - \frac{\eta}{\gamma} + \eta\right) \right] = \frac{-B}{2A}.$$

Therefore, the EE with the smaller value of s^* , denoted by (s_-^*, l_-^*) , is locally asymptotically stable and the EE with the larger value of s^* , (s_+^*, l_+^*) , is unstable when they exist.

In order to plot the regions of equilibria stability we consider curves $R_1 = 1$, $R_2 = 0$ and $R_3 = 0$, and define two variables $x = \frac{\alpha\xi}{\phi}$ and $y = \frac{\gamma}{\eta}$. By substituting x in $R_1 = 1$ and $R_2 = 1$, we obtain $x = \frac{1}{p}$ and $y = \frac{px}{px - 1}$ for $R_1 = 1$ and $R_2 = 1$, respectively, where $p = \frac{\alpha - \delta}{\alpha\xi}$. Similarly, y expresses $R_3 = 0$ in term of x , p and q . They are plotted together and all equilibria and stability are classified in Figure 2. The values of parameters used to plot these graphs are estimated in Section 4.

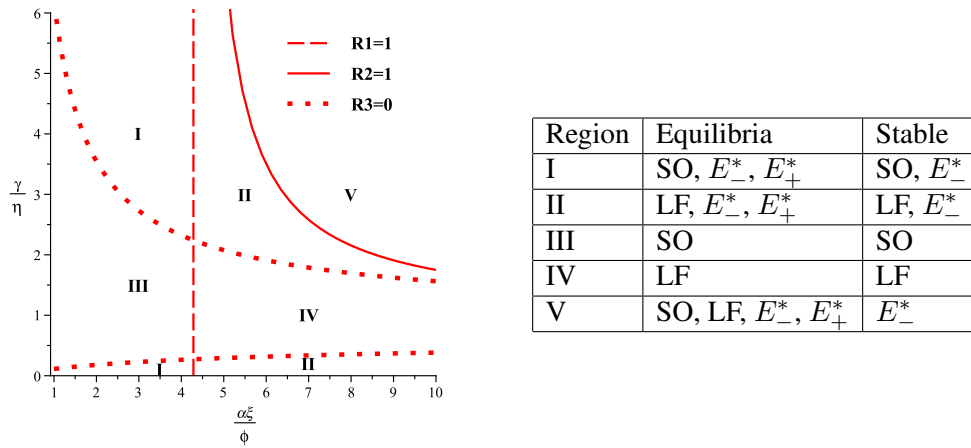

FIGURE 2. Regions and classification of Equilibria Stability with $\alpha = 0.5$, $\delta = 0.15$, $\xi = 3$, $\gamma = 0.1$, $\phi = 0.25$, and $\eta = 0.02$

3.3. Sensitivity. Our model contains two threshold conditions R_1 and R_2 . The sociological terms for these are tipping points because they provide a point at which a stable system turns to an unstable one or vice versa. Hence, in order to determine parameters to which our system is most sensitive we find the sensitivity indices of R_1 and R_2 for all parameters. To see how a small perturbation made to a parameter p affects a threshold condition R , we define the sensitivity index of R for p as

$$S_p = \frac{\partial R}{\partial p} \frac{p}{R}.$$

The analytic expressions of the sensitivity indices of all parameters with respect to R_1 are

$$S_\alpha = \frac{\alpha}{\alpha - \delta}, S_\delta = \frac{\delta}{\delta - \alpha} \phi^2, S_\phi = -1$$

and ones with respect to R_2 are

$$S_\alpha = \frac{1}{R_1(\alpha - \delta - \phi)}, S_\delta = -\frac{1}{R_1(\alpha - \delta - \phi)}, S_\phi = -\frac{1}{\alpha - \delta - \phi}, S_\gamma = 1, S_\eta = -\frac{1}{\eta}.$$

We apply the same set of parameters that generated Figure 2 and varied α to change the conditions of R_1 and R_2 and conclude that the system is most sensitive to α and η with respect to R_1 and R_2 , respectively, regardless of the threshold conditions, less than 1 or greater than 1. It is easily seen that the recruitment rate α dominates the transition from the S class to D , but this sensitivity analysis shows how important the role of η is. R_2 deals with D to L conversions and new individuals in L play a significant role in the acquisition of new protesters. This may explain why some countries tend to apply harsh punishment to protest leaders or negotiate with them as the best way to stop demonstrations.

3.4. Bifurcation. A bifurcation is a point in parameter space where equilibria appear, disappear or change stability. We plot the equilibrium values of l^* versus R_2 in Figures 3 and 4. The dotted curves plot l_+^* and are asymptotically stable. Whereas, solid curves plot l_-^* and they are unstable. We vary η and fix all other parameters as in Section 4 to create Figure 3 since the system is most sensitive to η with respect to R_2 . Figure 3 shows that the system may have two endemic equilibria if we have sufficient initial number of L individuals even if $R_2 < 1$, R_2 is interpreted as the average number of demonstrators that an individual in L would convert. One is stable even when R_2 is less than 1 if it exists. Figure 4 has all fixed values of parameters as in Section 4 with varied values of α . Both figures show a backward bifurcation and the comparison of two figures also show that the system is more sensitive to η than α .

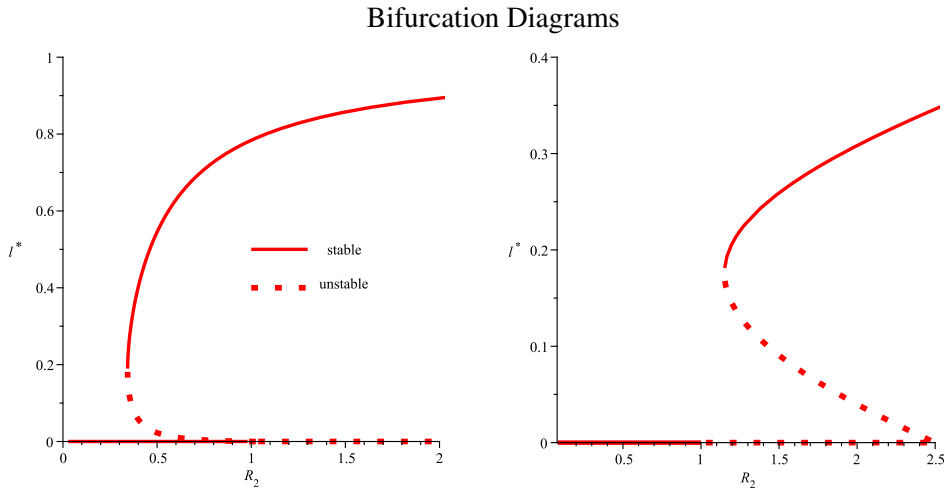

FIGURE 3. with $\eta = [0.001, 0.5]$

FIGURE 4. with $\alpha = [0.015, 0.8]$

4. PARAMETER ESTIMATION

In order to run simulations, all parameters must be estimated. As some of the parameters can be estimated only very roughly, our principle goal is to understand our mathematical analysis better with the simulations and to see how closely the model behavior corresponds to the actual observations.

We estimate the parameters of the model based on a variety of online data through Google-Aleema and international news reports from BBC, CBS, and ABC. Since the numbers of protesters reported vary significantly depending on the sources, we average them. We limit our estimations to the candlelight vigils and demonstrations that occurred in Seoul for 100 days beginning from May 2: $N = 15$ millions, inhabitants in Seoul, Incheon, and satellite cities in Gyeonggi-do who could participate in protests by public transportations [7][8]; $D = 1$ million, total protesters in the area for the durations considered; $L = 15,000$, total number of leaders who organized or staged a protest during the period considered; tens of protesters were arrested every day even if majority of them were released next day. Although there is no accurate form of quantifying data for peer driven recruitment rates and linear terms, by considering the increase or decrease in each class per unit time and the number of arrests, we estimate the following:

$$\alpha = 0.5, \gamma = 0.1, \phi = 0.25, \eta = 0.02, \delta = 0.15, \xi = 3$$

and use these values for all our graphs and simulations.

5. SIMULATION AND INTERPRETATION OF DYNAMICS

We plot the solution curves D and L to see the dynamics of the system. The initial conditions used are $S_0 = 14,902,000$, $D_0 = 100,000$, and $L_0 = 8,000$ and the unit of the vertical axis in the plots is thousands. Figure 5 uses the parameters estimated in Section 4 and we increase the value of η to 0.05 in Figure 6.

Both figures describe the rapid decrease of D when the issue is in the process of being resolved, but the decrease of L is very slow even with the increase of η . This phenomenon explains the sociological circumstances surrounding the protests. When the beef imports issue is resolved, the protesters have no reason to continue any form of demonstrations, but that is not the main issue of the L class members any more. The majority of class L might have used the beef issue as an outlet of their frustrations over the economy and new government along the process of the protests. Since what the individuals of the L class want varies, small protests consisting of individuals in L may occur for a while, but these protests without the support of the general public die out quickly.

6. CONCLUSION

In this paper we developed an epidemiological model to study the stability, sensitivity, and dynamics of the protests. By examining the property of equilibria and their stability, we derived threshold conditions which can be used to determine the prevalence of protests. If $R_1 < 1$, protests fall to zero. If $R_1 > 1$ and $R_2 < 1$, protests occur, but without leaders who may have

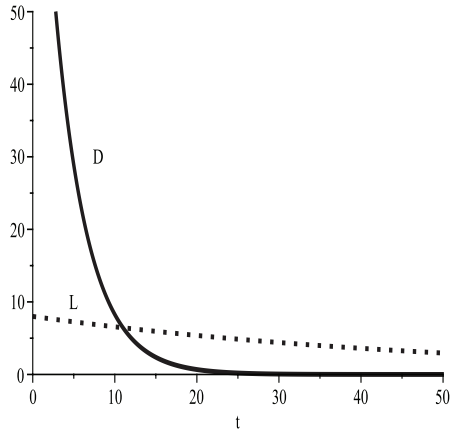
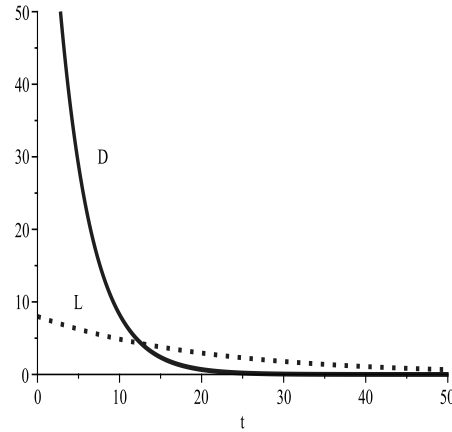
FIGURE 5. with $\eta = 0.02$ FIGURE 6. with $\eta = 0.05$

different agenda in addition to the beef issue. These protests are easily controlled when the issue is in the process of being resolved. If R_3 is positive and the initial number of leaders is sufficient, we may have a stable endemic equilibrium even when $R_2 < 1$. The system is most sensitive to η with respect to R_2 and the decrease of the L size is very slow even when there is no public support for the protests that they stage with their additional agenda. One of the main implications of this model is to control the L class by minding η if we want to avoid large scale prolonged demonstrations. That is, if we want strong lasting protests, one should recruit a large number of L individuals at the beginning. This model can be easily applied to other protests with a national agenda.

REFERENCES

- [1] "South Korea relaxes US beef ban", BBC News (18 April 2008)
- [2] "Transcript of remarks by agriculture secretary Mike Johanns concerning U.S. beef exports", United States Department of Agriculture
- [3] "MBC needs to acknowledge its mistakes", Chosun Daily News (May 21, 2008)
- [4] K. Kawachi, M. Seki, H. Yoshida, Y. Otake, K. Warashina, and H. Ueda, A Rumor Transition Model with Various Contact Interactions, *Journal of Theoretical Biology* 253 (2008)
- [5] A. Rapoport and L. Rebhun, On the Theory of Rumor Spread, *Bulletin of Mathematical Biophysics* 14 (1952)
- [6] Bauer, F., and C. Castillo-Chavez. *Mathematical Models in Population Biology and Epidemiology*, Springer-Verlag, NY 2001
- [7] R. Fortell, R. Green, and J. Pick. "Which are the largest? Why published populations for major world urban areas vary so greatly?", City Futures Conference, University of Illinois at Chicago, July 2004
- [8] Korean Statistical Information Service